



SMART LED BACK-LIT PANEL

► **DESIGN** - SMART RGBW LED BACK-LIT PANEL comes with a durable commercial grade housing resistant to rust and impact, anti-corrosion aluminum seamless rigid frame, anti-glare PC lens, and 0-10V dimmable driver with circuit overload, short circuit, and low-voltage protection, making it both safe and reliable. It is designed to operate on 120-277V circuits.

► **RGBW** - The fixture has RGBW design with APP control. You can easily select Red, Green, Blue, White (3,500K-5,000K) colors or its combinations, having 16.7 million colors in total. You can also choose lighting patterns and set up a schedule, having a great variety of good looking effects.

► **SMART CONTROL** - You can easily make grouping and schedule programming of the fixtures with Smart App control. The fixture is also compatible with Alexa and Google Assistant.

► **INSTALLATION** - This fixture has three different mounting options: recessed, suspended, and surface.

► **ADVANTAGES** - With calculated lifespan up to 180,000 hours, these fixtures are made to last decades under normal operation! ASD provides a 5-year limited warranty along with UL and DLC Premium certifications to guarantee top quality products and safety!

<i>Catalog number</i>	
<i>Notes</i>	
<i>Type</i>	



Model	Type	Watts	Voltage	Dimmable	Lumens	CCT	Finish	Dimensions (LxWxH)
ASD-BLP-22D35SM-RGBW-2P	2x2	35W	120-277 V	0-10 V	up to 4,420 lm	Red-Green-Blue-White-3,500-5,000 K	White	23-3/4" x 23-3/4" x 1-3/8"
ASD-BLP-24D40SM-RGBW-2P	2x4	40W	120-277 V	0-10 V	up to 4,961 lm	Red-Green-Blue-White-3,500-5,000 K	White	47-3/4" x 23-3/4" x 1-3/8"

For detailed luminous flux information please refer to Annex 1, page 3.

ORDERING INFORMATION

Model	UPC	Pcs. per carton	Carton size	Carton weight
ASD-BLP-22D35SM-RGBW-2P	810128116640	4	24.6" x 24.8" x 3.2"	10.6 lbs
ASD-BLP-24D40SM-RGBW-2P	810128116664	4	48.6" x 24.8" x 3.2"	18.1 lbs

ACCESSORIES:

Model	Description	UPC	Pcs. per carton	Carton size	Carton weight	GTIN 14
ASD-FELP22-L	Surface mounting low frame for 2x2 panels	819201021581	9	25.2" x 6.5" x 7.7"	28.8 lbs	10819201021588
ASD-FELP24-L	Surface mounting low frame for 2x4 panels	819201021598	9	48.8" x 5.9" x 7.7"	45.2 lbs	10819201021595
ASD-CHS4	Ceiling hanging set 39.37"	859961005148	50	10.4" x 10.4" x 7.7"	23.7 lbs	10859961005145

For most up-to-date spec sheets please refer to asd-lighting.com



SMART LED BACK-LIT PANEL



PRODUCT SPECIFICATIONS:

Construction & Materials					
Housing	Aluminum				
Lens	PS				
Finish	White				
Weight	ASD-BLP-22D35SM-RGBW-2P	8.4 lbs (3.8 kg)			
	ASD-BLP-24D40SM-RGBW-2P	15 lbs (6.8 kg)			
Environmental system					
Work environment	Suitable for Damp Locations				
Operating temperature	-4°F to 104°F (-20°C to 40°C)				
L-70 Life	R > 54,000 hrs; C > 144,000 hrs				
Optical system					
Color temperature	From Red-Green-Blue-White-3,500-5,000 K with smart app				
CRI	> 80				
Electrical system					
Input voltage	120-277 V				
Max input current	0.48 A				
Inrush current (Action time)	20 A (0.2 S)				
Off state power	0W				
Power consumption	ASD-BLP-22D35SM-RGBW-2P	35W			
	ASD-BLP-24D40SM-RGBW-2P	40W			
Power factor	> 0.9				
Output voltage	20-50 V				
Max output current	ASD-BLP-22D35SM-RGBW-2P	0.7 A			
	ASD-BLP-24D40SM-RGBW-2P	0.81 A			
Surge protection DM/CM	1 kV / 2 kV				
Dimming compatible controls					
Brand	Maxxima	Keygma	Lutron	Leviton	Eaton
Models	MEW-DM600LV	KGM-1A010V	DVSTV-WH	IP710-DLZ	DF10P-C1
Regular and voluntary certifications					
5-year limited warranty					
DesignLights Consortium (DLC) listed (Classification: Premium)					
Main: Indoor luminaires; General application: Troffer;					
Primary use: Luminaires for ambient lighting of Interior commercial spaces					
UL certified E473854					
FCC compliant					

PACKAGE CONTENTS:

Description	Q-ty
Smart RGBW LED Back-Lit Flat Panel	2
Box	1

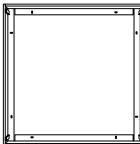
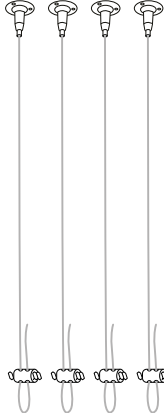
ACCESSORIES (sold separately):

Surface mounting low frame for 2x2 ASD-FELP22-L	Ceiling hanging set 39.37" ASD-CHS4
	
for 2x4 ASD-FELP24-L	
	

ACCESSORY COMPATIBILITY LIST:

Accessories	Surface mounting low frame for 2x2 panels ASD-FELP22-L	Surface mounting low frame for 2x4 panels ASD-FELP24-L	Ceiling hanging set 39.37" ASD-CHS4
Models			
ASD-BLP-22D35SM-RGBW-2P	•		•
ASD-BLP-24D40SM-RGBW-2P		•	•

For most up-to-date spec sheets please refer to asd-lighting.com



SMART LED BACK-LIT PANEL

INSTALLATION GUIDE

IMPORTANT SAFETY INFORMATION:

Please read all the instructions below before installation.

- ▶ Make sure that the supply voltage corresponds to the rated product voltage.
- ▶ The product must be installed by a qualified electrician in accordance with the National Electrical Code and corresponding local codes.
- ▶ If the product is damaged, do not use it.

⚠ WARNING

Risk of personal injury – read and follow all warnings and installation instructions. Keep or give to the owner for future reference.

Risk of cuts: Wear gloves to prevent cuts or abrasions when removing from carton, handling, installing, and maintaining this product.

Risk of electric shock: This product must be installed in accordance with the applicable installation code by a person familiar with the construction and operation of the product and the hazards involved.

Risk of Fire: Minimum 194°F supply conductors. Consult a qualified electrician to ensure correct branch circuit conductor.

ASD® assumes no responsibility for claims arising out of improper or careless Installation or handling of this product.

ELECTRICAL SCHEMATIC DIAGRAM:

BLP-SM multiple fixture connection

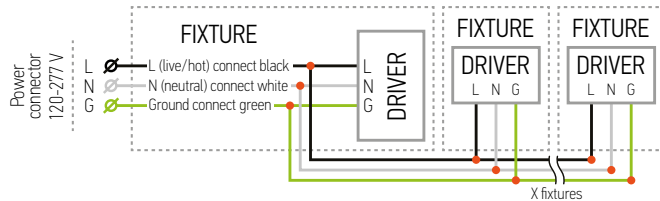

Linking limits: up to 20 panels can be linked together. Total power of LED Panels shall not exceed the wattage of dimmer.

Download ASD SMART app and add the fixture to it according to the manual (download manual and app from the links or scan the QR codes below).

Adding the fixture to ASD SMART APP:

1. Download ASD SMART APP
2. Tap "+" in the upper-right hand corner.
3. Select "Add a device" section.
4. Follow APP instructions.
5. The fixture must be found by the APP and appear on the screen.
6. Adding ASD Smart RGBW LED Back-Lit Flat Panel is complete.

[Manual](#)



[ASD SMART app download Android](#)



[ASD SMART app download iOS](#)



RECESSED MOUNT INSTALLATION:

1. Lift all mounting clips along the edges of the panel. Turn the mounting clip head.
2. Remove the knockout hole on box with a screwdriver, remove screw and take out the driver cover. Connect the wires inside the driver box: Black to Black, White to White, Green to Green.
3. Cover the driver box and tighten it with a screwdriver, finish connection.

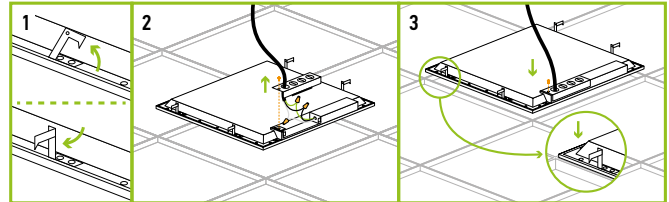

SURFACE MOUNT INSTALLATION

ASD-FELP22-L ASD-FELP24-L sold separately:

1. Connect 3 pieces of the frame to the ceiling using four screws.
2. Connect the panel wires as shown in electrical schematic diagram and insert panel into frame.
3. Attach the fourth piece and secure with screws. Power on to ensure installation is complete.

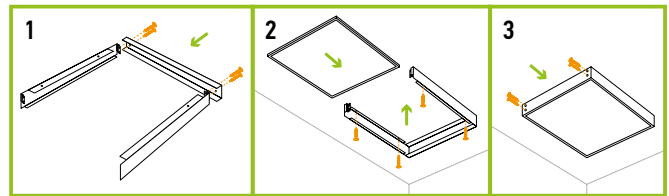

* Must remove earthquake hook before installing surface mount frame.

SUSPENDED MOUNT INSTALLATION

ASD-CHS4 sold separately:

1. Insert the wall plugs (not included) into the ceiling and secure the cable to the ceiling.
2. Lock the suspension cable to the clip. Adjust the cable length to meet the height requirements. Attach the cable to the ceiling.

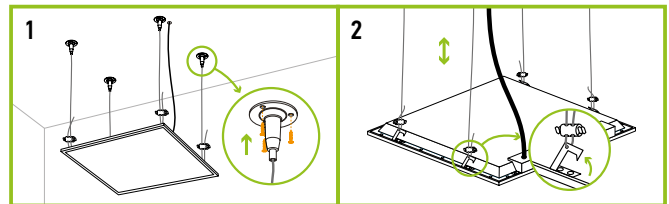

* For 2x4 installation please use 2 pcs of Ceiling Hanging set.

ANNEX 1

Model	Watts	3,500 K	4,000 K	5,000 K
ASD-BLP-22D35SM-RGBW-2P	35W	4,368 lm	4,420 lm	4,282 lm
ASD-BLP-24D40SM-RGBW-2P	40W	4,831 lm	4,918 lm	4,961 lm

For most up-to-date spec sheets please refer to asd-lighting.com